

# Válvulas de Retención de Doble Plato / Dual Plate Check Valves



## APLICACIONES / APPLICATIONS

Estaciones de bombeo y redes de distribución para agua limpia, irrigación (aguas filtradas).

*Pumping stations and networks for clean water distribution, irrigation (filtered water).*

Redes contra incendios / Fire protection networks.

Compresores con baja presión / Air-compressors.

Aplicaciones con varios fluidos (a consultar).

*Applications with different fluids (to be consulted).*

Asegurando la protección de la bomba contra la inversión del fluido.

*Ensuring the protection of pumps against flow inversion.*

## DATOS TÉCNICOS / TECHNICAL DATA

Diseño / Design: EN14341(EN12516) / API594 (ASME B16.34).

Distancia entre bridas / Face to Face: En558 series 16 / API594.

Dimensiones: DN 40 a DN 1400 / Range: DN 40 to DN 1400.

Tipo de conexión: Wafer o Bridas PN6 a PN100 según EN1092-1 / PN6 a PN 40 ISO7005-1 / BS4504 Sect3.2 / ANSI125# to 600# acc. to ASME B16.1/B16.5 / B16.47 (JIS a consultar).

*Connections: Wafer or Flanged PN6 to PN100 acc. to EN1092-1/PN6 to Pn40 ISO7005-1 / BS 4504 sect 3.2 ansi125# to 600# acc. to ASME B16.1/B16.5 / B16.47 (JIS to inquire).*

Máxima presión de trabajo dependiendo de la construcción (a consultar).

*Maximum working pressures depending on material construction.*

Límites de temperatura: -20°C a 120°C (otras temperaturas consultar).

*Operating temperatures -20°C +120°C (for other temperatures inquire).*

Pruebas / Testing: En12266(ISO5208) o/or API598.

Presión mínima de estanqueidad: 0,3 a 0,5 bar.

*Minimum backpressure for tightness: 0,3 to 0,5 bar.*

Marcaje / Marking: EN-19 / ASME B16.34 (MSS SP25).

## VENTAJAS TÉCNICAS / TECHNICAL PERFORMANCES

Distancia entre caras muy corta con buenas características hidráulicas.

*Short Face To Face connection with good hydraulic performance.*

Baja pérdida de carga / Low pressure drop.

Compacta / Compactness.

Asiento vulcanizado en el cuerpo / Seal vulcanized on the seat of the body.

Cierre ayudado por resorte (reduce el golpe de ariete) / Springs helping closing the plates (reducing waterhammer).

Dos resortes por válvula para equilibrar la fuerza en cada plato / Two springs for equilibrated forces on the plates.

Topes en los platos para reducir esfuerzos en las orejetas de giro.

*Stops on plates to reduce friction between ears of plates and shaft.*

Flujo simétrico conseguido por el eje tope (DN 350 y superiores) o por pieza tope (hasta DN 300) a la apertura total de los platos.

*Symmetrical flow obtained by the centering pin when the plates are fully opened.*

Instalación horizontal o vertical / Horizontal and Vertical installation in pipeline.

Cáncamo para fácil manipulación a partir de DN 250 / Lifting rings from DN 250.

## CURVAS PERDIDA DE CARGA / PRESSURE DROP CURVE EN 588 SERIES 16

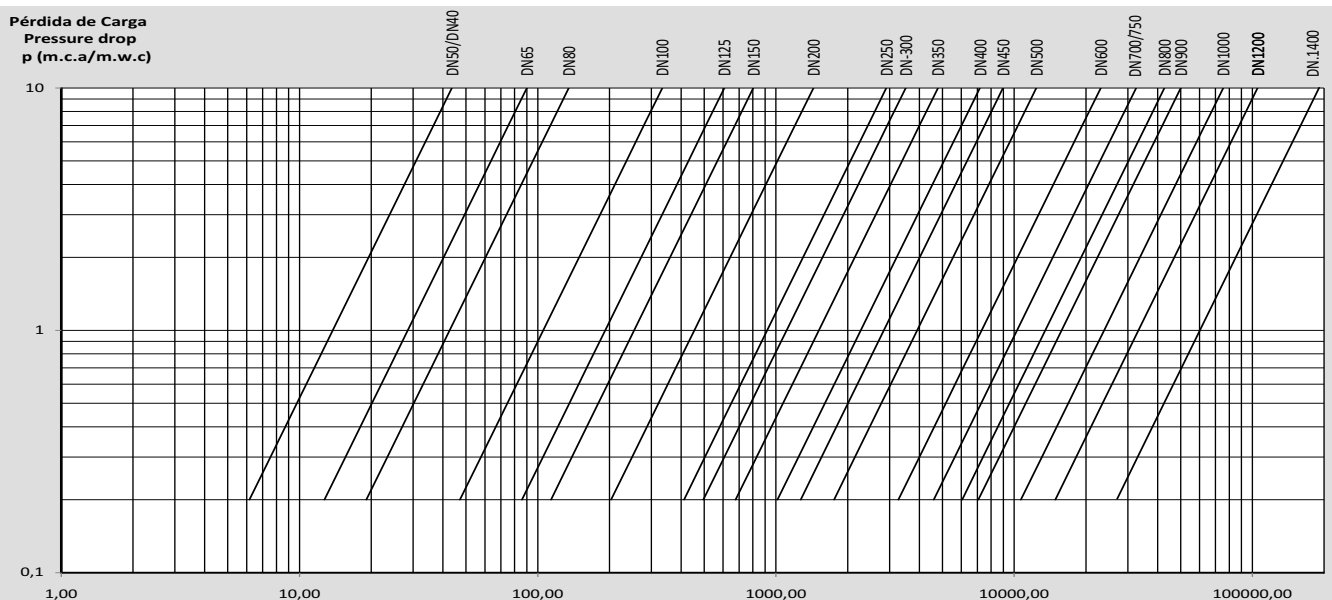

Datos para agua en condiciones normales  
Graphic for water in normal conditions

CAUDAL/FLOW (m<sup>3</sup>/h)

# Wafer EN 558 SERIES 16 / Wafer EN 558 SERIES 16

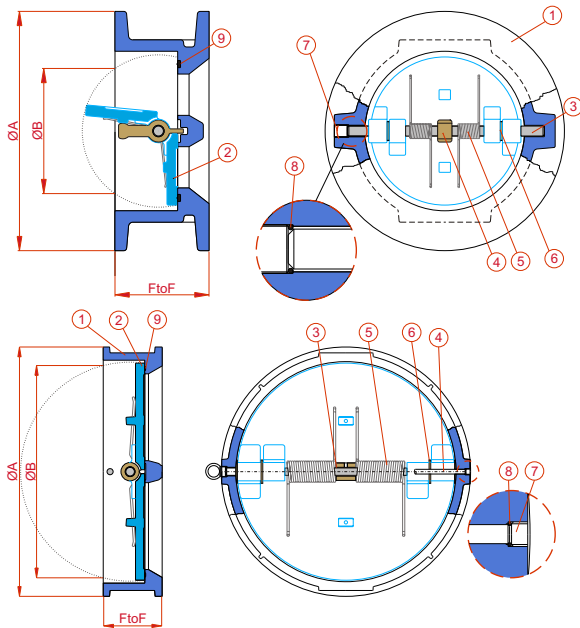

DIMENSIONES / DIMENSIONS WAFER EN 558 SERIES16											
DN	ØA (mm)				ØB (mm)	F to F (mm)	Kv (m³/h)	CRACKING PRESSURE (mbar)	WEIGHT (kg. aprox.)		
	PN10	PN16	PN25	ANSI150#					PN10/16	PN25	ANSI150#
40	94				46	43	44	3,21		1,1	
50	108				46	43	44	3,21		1,5	
65	129				62	46	90	3,05		1,9	
80	143				70	64	135	2,85		3	
100	164				90	64	333	2,42		4	
125	194				110	70	606	2,17		6	
150	220				130	76	803	1,96		8,5	
200	275				283	195	89	1435	1,55	15	
250	330				338	337	245	2905	1,43	27	
300	381				402	407	292	114	3504	1,29	34
350	440				460	448	340	127	4786	1,17	53
400	491				514	511	380	140	7179	1,08	68
450	540	556	565	546	435	152	8974	0,98	93		
500	596	618	625	603	490	152	12939	0,9	119		
600	696	736	733	715	580	178	23076	0,79	175		
700	809	807	834	832	670	229	32136	0,76	295		
800	920	912	942	938	775	241	42735	0,7	385		
900	1020	1014	1042	1046	870	241	50000	0,67	430		
1000	1126	1130	1155	1155	965	300	75384	0,63	630		
1200	1344	1344		1360	1150	350	105128	0,59	1030		
1400	1548	1542		1605	1350	390	154700	0,53	1570		

Bridas ANSI según B16.5 <Dn600 y B16.47 Series A> DN600 / Flanges ANSI acc. to B16.5 <Dn600 and B16.47 Series A> DN600

## ESTANDAR / STANDARD DN40-DN300

Nº PARTE / PART

DN	1. CUERPO/BODY			2. PLATOS/PLATES			3. EJE/SHAFT	4. TOPE/KEY	5. RESORTES/SPRINGS	6. ARANDELAS/WASHERS	7. TAPON/PLUG	8. JUNTA/O-RING	9. ASIENTO/SEAT
	PN10	PN16	PN25	PN10	PN16	PN25							
40	EN-GJS-400-15			WCB A-216			AISI-304	CF-8M	AISI-302	AISI-304	ACERO/STEEL	NBR	BUNA-N
50													
65													
80													
100													
125													
150													
200	EN-GJL-250			EN-GJS-400-15			AISI-304	CF-8M	AISI-302	AISI-304	ACERO/STEEL	NBR	BUNA-N
250													
300													

## ESTANDAR / STANDARD DN350-DN1200

Nº PARTE / PART

DN	1. CUERPO/BODY			2. PLATOS/PLATES			3. EJE/SHAFT	4. TOPE/STOP PIN	5. RESORTES/SPRINGS	6. ARANDELAS/WASHERS	7. TAPON/PLUG	8. JUNTA/O-RING	9. ASIENTO/SEAT
	PN10	PN16	PN25	PN10	PN16	PN25							
350	EN-GJL-250			EN-GJS-400-15			AISI-304	AISI-304	AISI-302	AISI-304	ACERO/STEEL	NBR	BUNA-N
400													
450													
500													
600													
700													
800													
900	EN-GJS-400-15			WCB A-216			AISI-304	AISI-304	AISI-302	AISI-304	ACERO/STEEL	NBR	BUNA-N
1000													
1200													

## NO ESTANDAR / NON STANDARD DN40-DN1200

Nº PARTE / PART

DN	1. CUERPO/BODY	2. PLATOS/PLATES	3. EJE/SHAFT	4. TOPE/KEY	5. RESORTES/SPRINGS	6. ARANDELAS/WASHERS	7. TAPON/PLUG	8. JUNTA/O-RING	9. ASIENTO/SEAT
40	INOXIDABLE /STAINLESS STEEL, DUPLEX	INOXIDABLE /STAINLESS STEEL, DUPLEX			INCONEL			EPDM, VITON	VITON
50									
65									
80									
100									
125									
150									
200	NODULAR/DUCTILE, ACERO/STEEL, INOXIDABLE /STAINLESS STEEL, DUPLEX, BRONCE-ALU/BRONZE-ALU	ACERO/STEEL, INOXIDABLE/STAINLESS STEEL, DUPLEX, BRONCE-ALU/BRONZE-ALU	INOXIDABLE/STAINLESS STEEL, DUPLEX, BRONCE-ALU/BRONZE-ALU	INOXIDABLE/STAINLESS STEEL, DUPLEX, BRONCE-ALU/BRONZE-ALU	AISI-316, INCONEL			EPDM, VITON, KLIN GERIT	EPDM, VITON, NEOPRENO, METAL-METAL
250									
300									
350									
400									
450									
500									
600	NODULAR ENGOMADA/ DUCTILE IRON RUBBER LINED, ACERO/STEEL, DUPLEX, INOXIDABLE/STAINLESS STEEL, BRONCE-ALU/BRONZE-ALU	ACERO/STEEL, INOXIDABLE/STAINLESS STEEL, DUPLEX, BRONCE-ALU/BRONZE-ALU	INOXIDABLE/STAINLESS STEEL, DUPLEX, BRONCE-ALU/BRONZE-ALU	INOXIDABLE/STAINLESS STEEL, DUPLEX, BRONCE-ALU/BRONZE-ALU	AISI-316, INCONEL			EPDM, VITON, KLIN GERIT	EPDM, VITON, NEOPRENO, METAL-METAL
700									
800									
900									
1000									
1200									

# Bridas EN 558 SERIES 16 / Flanged EN 558 SERIES 16

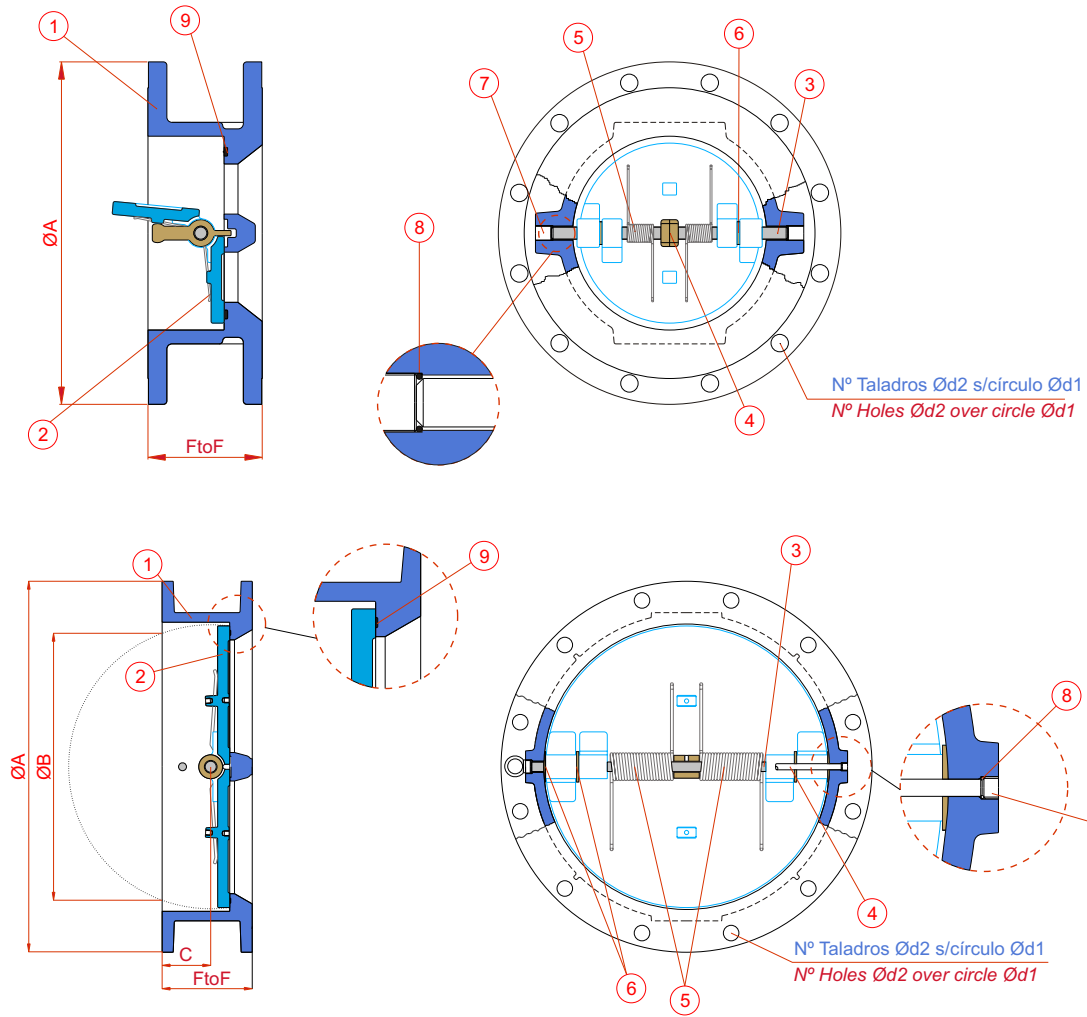

DIMENSIONES BRIDAS / DIMENSIONS FLANGED EN 558 SERIES 16										TALADRO BRIDAS / FLANGE DRILLING											
DN	ØA (mm)				ØB (mm)	F to F (mm)	Kv (m³/h)	CRACKING PRESSURE (mbar)	WEIGHT (kg. aprox.)			PN10		PN16		PN25		ANSI150#			
	PN10	PN16	PN25	ANSI150#					PN10/16	PN25	ANSI150#	Ød1	Nº	Ød2	Ød1	Nº	Ød2	Ød1	Nº	Ød2	Ød1
250	395	400	425	404	245	114	2905	1,43	consultar / inquire	350	12	23	355	12	27	370	12	30	362	12	7/8"
300	445	455	485	479	292	114	3504	1,29		400	12	23	410	12	27	430	16	30	432	12	7/8"
350	505	520	555	530	340	127	4786	1,17		460	16	23	470	16	27	490	16	33	476	12	1"
400	565	580	620	593	380	140	7179	1,08		515	16	27	525	16	30	550	16	36	540	16	1"
450	615	640		631	435	152	8974	0,98		565	20	27	585	20	30	600	20	36	578	16	1 1/8"
500	670	715	730	694	490	152	12393	0,9		620	20	27	650	20	33	660	20	36	635	20	1 1/8"
600	780	840	845	807	580	178	23076	0,79		725	20	30	770	20	36	770	20	39	749	20	1 1/4"
700	895	910	960	921	670	229	32136	0,76		840	24	30	840	24	36	875	24	42	863	28	1 1/4"
800	1015	1025	1085	1053	775	241	42735	0,7		950	24	33	950	24	39	990	24	48	978	28	1 1/2"
900	1115	1125	1185	1161	870	241	50000	0,67		1050	28	33	1050	28	39	1090	28	48	1086	32	1 1/2"
1000	1230	1255	1320	1280	965	300	75384	0,63		1160	28	36	1170	28	42	1210	28	56	1200	36	1 1/2"
1200	1455	1485			1150	350	105128	0,59		1380	32	39	1390	32	48						

BRIDAS / FLANGES DN250-DN1200									
Nº PARTE / PART									
DN	1. CUERPO/BODY	2. PLATOS/PLATES	3. EJE/SHAFT	4. TOPE/STOP PIN	5. RESORTES/SPRINGS	6. ARANDELAS/WASHERS	7. TAPON/PLUG	8. JUNTA/O-RING	9. ASIENTO/SEAT
250	EN-GJL-250, EN-GJS-400-15, ACERO / STEEL, INOXIDABLE / STAINLESS STEEL, DUPLEX, BRONCE-ALU / BRONZE-ALU	EN-GJS-400-15, ACERO / STEEL, INOXIDABLE / STAINLESS STEEL, DUPLEX, BRONCE-ALU / BRONZE-ALU	INOXIDABLE / STAINLES STEEL, DUPLEX, BRONCE-ALU / BRONZE-ALU	INOXIDABLE / STAINLES STEEL, DUPLEX, BRONCE-ALU / BRONZE-ALU	AISI-302, AISI-316, INCONEL	INOXIDABLE / STAINLESS STEEL, DUPLEX, BRONCE-ALU / BRONZE-ALU	ACERO/STEEL, INOXIDABLE / STAINLESS STEEL, DUPLEX, BRONCE-ALU / BRONZE-ALU	NBR, EPDM, VITON, KLINGERIT	NBR, EPDM, VITON, NEOPRENO, METAL-METAL
300									
350									
400									
450									
500	NODULAR ENGOMADA / DUCTILE IRON RUBBER LINED, ACERO/STEEL, INOXIDABLE / STAINLESS STEEL, DUPLEX, BRONCE-ALU / BRONZE-ALU	EN-GJS-400-15, ACERO / STEEL, INOXIDABLE / STAINLESS STEEL, DUPLEX, BRONCE-ALU / BRONZE-ALU	INOXIDABLE / STAINLES STEEL, DUPLEX, BRONCE-ALU / BRONZE-ALU	INOXIDABLE / STAINLES STEEL, DUPLEX, BRONCE-ALU / BRONZE-ALU	AISI-302, AISI-316, INCONEL	INOXIDABLE / STAINLESS STEEL, DUPLEX, BRONCE-ALU / BRONZE-ALU	ACERO/STEEL, INOXIDABLE / STAINLESS STEEL, DUPLEX, BRONCE-ALU / BRONZE-ALU	NBR, EPDM, VITON, KLINGERIT	NBR, EPDM, VITON, NEOPRENO, METAL-METAL
600									
700									
800									
900									
1000									
1200									

# Wafer - Bridas API 594 / Wafer - Flanged API 594

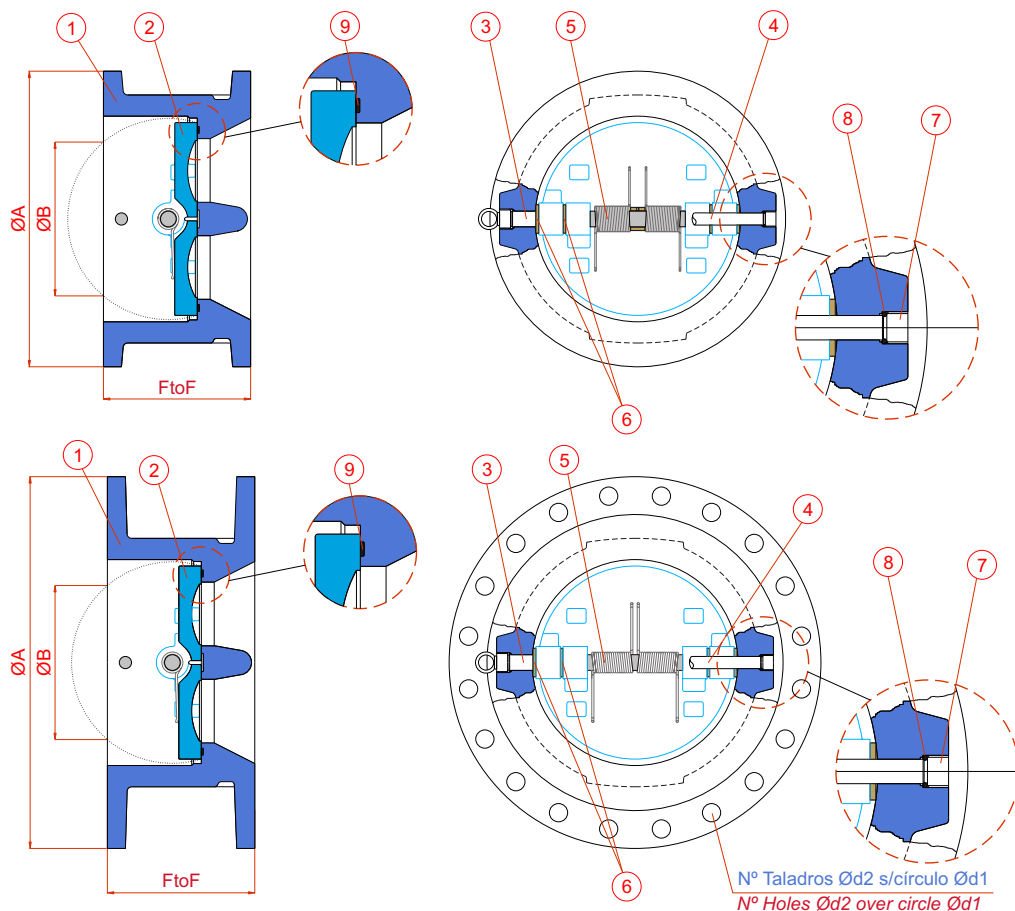

DIMENSIONES / DIMENSIONS WAFER API594

DN	ØA (mm)				ØB (mm)				F to F (mm)				peso/weight(kg) ANSI 600# /PN100	Kv(m³/h)				
	ANSI 150#	ANSI 300#	PN40	ANSI 600#	PN100	ANSI 150#	ANSI 300#	ANSI 600#	PN100	ANSI 150#	ANSI 300#	PN40		ANSI 600#	PN100	ANSI 150#	ANSI 300# /PN40	ANSI 600# /PN100
50	103		108		121	30				60				3	39			
80	137	143	143	146	156	40				73				6	128		123	
100	170	179	169	190	183	88		88		73		80		10	316		188	
150	220	248	224	265	260	112		105		98	98	98	137	137	38	743	521	
200	275	306	293	318	327	175		180		127	127	127	165	165	47	1367	1162	
250	338	360	355	397	394	210		230		146	146	146	213	213	92	2735	1709	
300	405	419	419	455	460	270		280		181	181	181	229	229	127	3376	2222	
350	450	484	476	490	512	300	320	320	315	315	184	222	222	273	273	166	4572	3632
400	515	538	548	562	572	372	370	370	360	360	191	232	232	305	305	255	6837	5213
450	543	595	572	610	628	416	430	430	402	402	203	264	264	362	362	390	8717	8376
500	607	652	630	680	706	560	460	460	450	450	213	292	292	368	368	600	12051	11623
600	713	772	748			580	550	550			222	318	318				22222	21709
700	826	895	853			640	662	662			321	305	305				29914	

DIMENSIONES BRIDAS API594 / DIMENSIONS FLANGED API594

DN	ØA (mm)		ØB (mm)		F to F (mm)		Kv(m³/h)		WEIGHT (kg. aprox.)		TALADRO BRIDAS / FLANGE DRILLING					
	ANSI 150#	ANSI 600#	ANSI 150#	ANSI 600#	ANSI 150#	ANSI 600#	ANSI 150#	ANSI 600#	ANSI 150#	ANSI 600# / PN100	ANSI 150#		ANSI 600#			
											Ød1	Nº	Ød2	Ød1	Nº	Ød2
250	403	504	210	230	146	213	2735	1709	80	180	362	12	7/8"	432	16	1"1/4
300	479	559	270	280	181	229	3376	2222	122	240	432	12	7/8"	489	20	1"1/4
350	530	599	300	315	184	273	4572	3632	140	380	476	12	1"	527	20	1"5/8
400	593	681	372	360	191	305	6837	5213	170	450	540	16	1"	603	20	1"1/2
450	631	738	416	402	203	362	8717	8376	205	595	578	16	1"1/8	654	20	1"5/8
500	694	807	560	450	213	368	12051	11623	265	750	635	20	1"1/8	724	24	1"5/8
600	807		580		222		22222	21709	500		749	20	1"1/4			
700	921		640		321		29914		990		863	28	1"1/4			

WAFER-BRIDADA / WAFER-FLANGED DN250-DN700

Nº PARTE / PART

DN	1. CUERPO/BODY	2. PLATOS/PLATES	3. EJE/SHAFT	4. TOPE/STOP PIN	5. RESORTES/SPRINGS	6. ARANDELAS/WASHERS	7. TAPON/PLUG	8. JUNTA/O-RING	9. ASIENTO/SEAT
250	EN-GJS-400-15, ACERO / STEEL, INOXIDABLE / STAINLESS STEEL, DUPLEX, BRONCE-ALU / BRONZE-ALU	EN-GJS-400-15, ACERO / STEEL, INOXIDABLE / STAINLESS STEEL, DUPLEX, BRONCE-ALU / BRONZE-ALU	INOXIDABLE / STAINLES STEEL, DUPLEX, BRONCE-ALU / BRONZE-ALU	INOXIDABLE / STAINLES STEEL, DUPLEX, BRONCE-ALU / BRONZE-ALU	AISI-302, AISI-316, INCONEL	INOXIDABLE / STAINLESS STEEL, DUPLEX, BRONCE-ALU / BRONZE-ALU	ACERO/STEEL, INOXIDABLE / STAINLESS STEEL, DUPLEX, BRONCE-ALU / BRONZE-ALU	NBR, EPDM, VITON, KLINGERIT	NBR, EPDM, VITON, NEOPRENO, METAL-METAL
300									
350									
400									
450									
500									
600									
700									

DUAL PLATE CHECK VALVE API 594 ANSI150#/300#

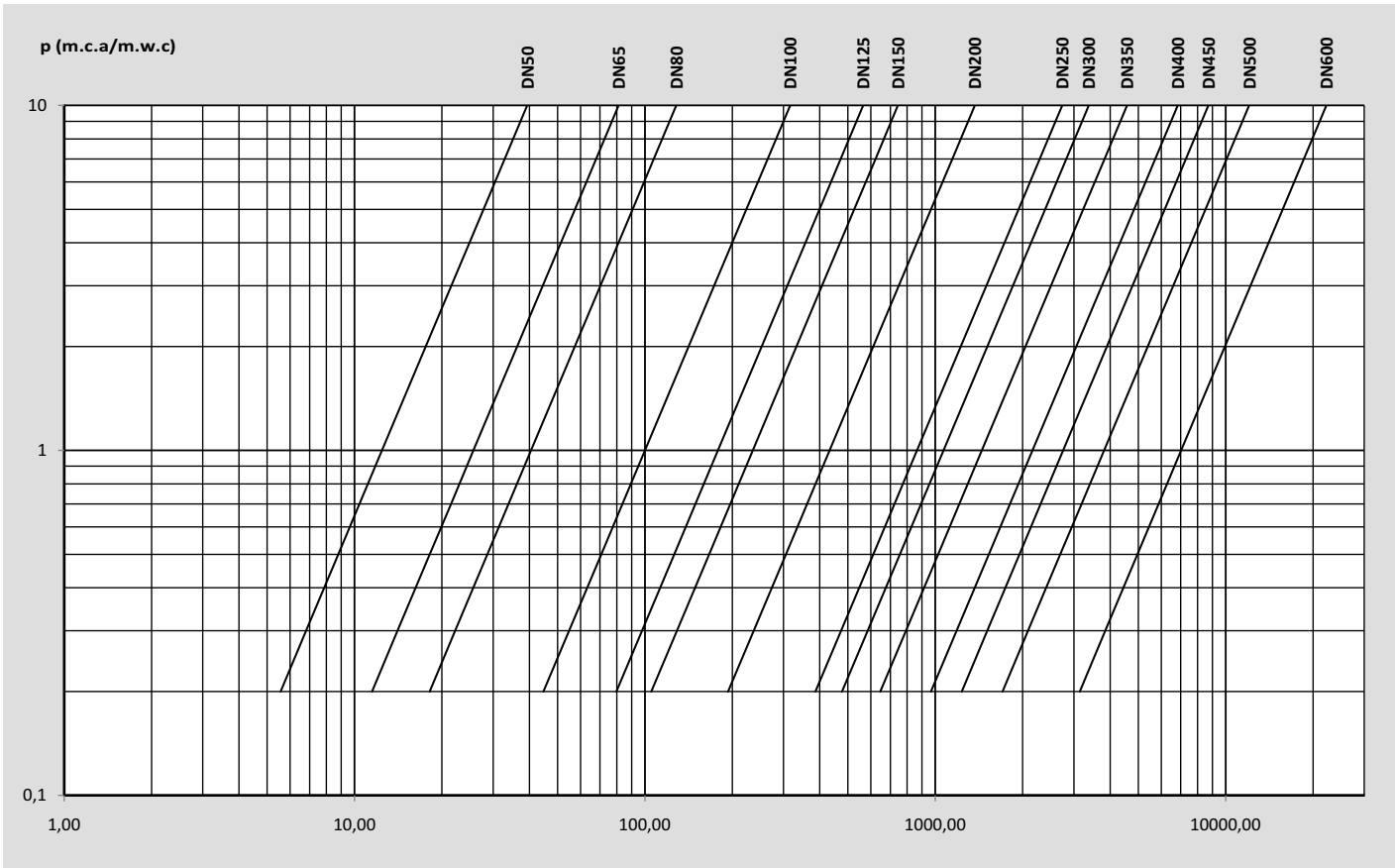

CAUDAL/FLOW (m<sup>3</sup>/h)

Datos para agua en condiciones normales  
 Graphic for water in normal conditions

DUAL PLATE CHECK VALVE API 594 ANSI600#

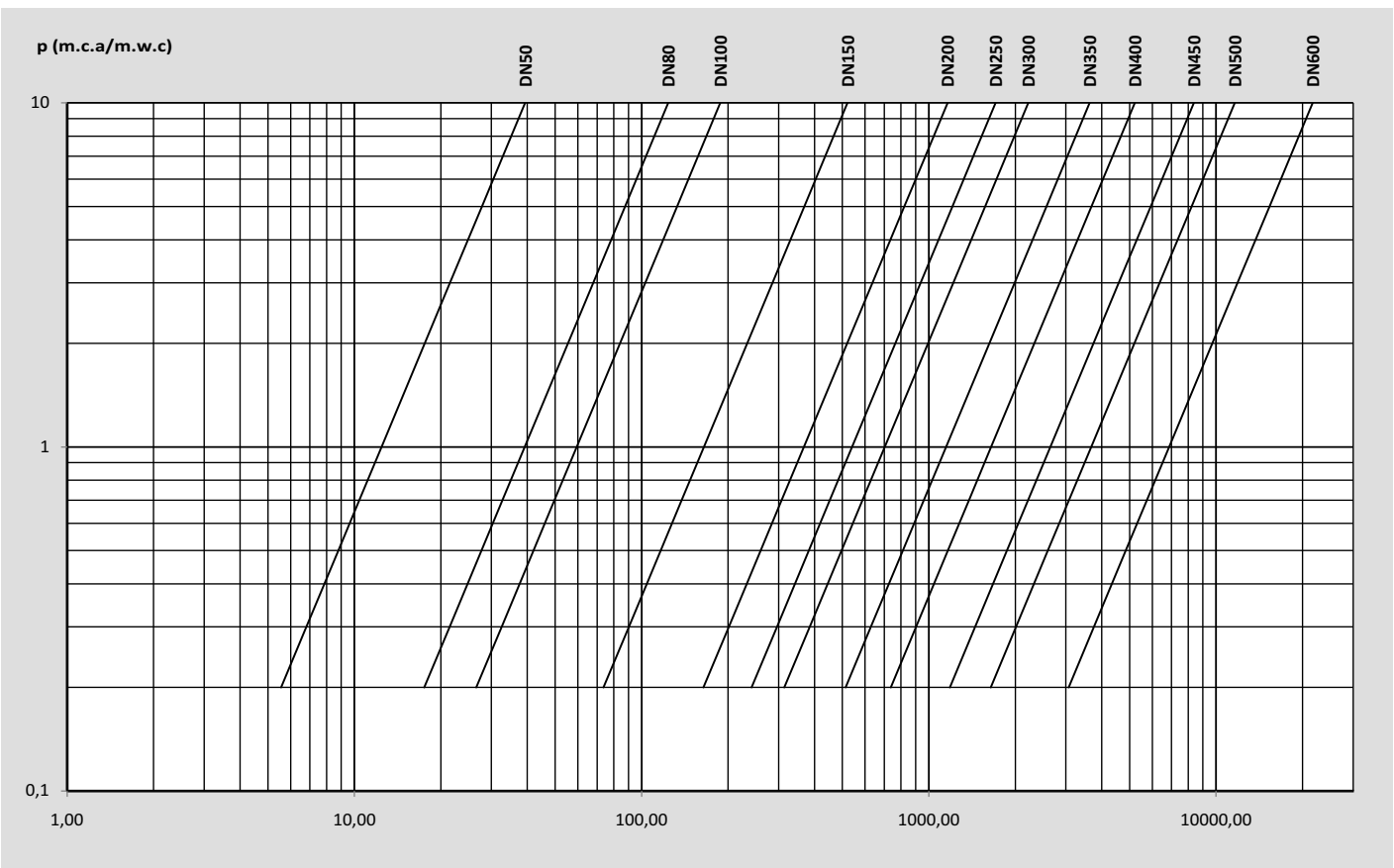

CAUDAL/FLOW (m<sup>3</sup>/h)

## Doble plato engomada / *Rubber lined Dual plate Check valves*

El elevado coste y la constante fluctuación en los precios de las materias primas, utilizadas para fundir materiales aleados resistentes a la corrosión, hace necesario buscar alternativas más económicas en otros tipos de construcciones.

Castflow valves ha desarrollado sus válvulas de retención de doble plato con el mismo sistema aplicado a las válvulas de mariposa de anillo envolvente, el cual consiste en cuerpos de fundición recubiertos interiormente de caucho. De esta forma y dependiendo del tamaño de la válvula, conseguiremos reducir el coste de las mismas entre un 15% y 35% en comparación con la misma válvula con el cuerpo en un material aleado. El sistema de cojinetes especialmente desarrollado para la válvula engomada garantiza una estanqueidad total en la zona más sensible a posibles fugas (zonas de paso de ejes). Con este sistema aplicado a la válvula de doble plato, se consigue un desgaste menor que en el caso de la válvula de mariposa de anillo envolvente, debido a que en las mariposas la estanqueidad es dinámica por el movimiento del eje conectado a la mariposa, mientras que en la válvula de retención de doble plato la estanqueidad es estática.

Castflow Valves ha desarrollado esta versión en un principio para las válvulas de baja presión (máximo PN10) y en las dimensiones desde DN300 a DN1200. Otros diámetros y presiones a consultar.

The elevated costs and continuous variation in the prices of prime materials used for castings of alloyed materials for corrosion resistance is motivation to look for alternatives more economical or other type of constructions.

Castflow valves therefore is producing the dual plate check valve with the same system that applies the butterfly valve with encircling liner. Meaning the body internally coated with rubber. By this application costs can be reduced between 15% and 35% of the total valve cost compared with the body completely in alloy. The special bushings ensure the total tightness in the area that is most affective to possible leaks (shaft passages). With this system applied on the dual plate check valves wear is even less than on the butterfly valves. The tightness of the butterfly valves is dynamic due to the fact the shaft is rotating to move the disc. In the dual plate this tightness is static as the shafts do not rotate.

Castflow valves developed the range from D300 up to DN1200 and for maximum pressures up to PN10. (Others to be inquired).

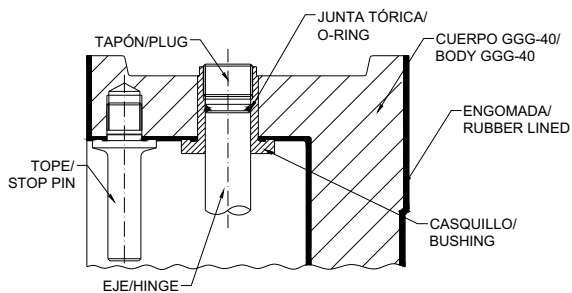

## Indicadores de posición / *position indicators*

En nuestras válvulas de doble clapeta tenemos la posibilidad de preparar las válvulas con unos casquillos especiales para la conexión de sensores de proximidad inductivos, (también pueden ir suministrados por Castflow Valves). El casquillo garantiza la estanqueidad entre el cuerpo y el propio sensor. Además es regulable para el

Our dual plate check valves can be prepared with special bushing in order to assemble inductive sensors for proximity, (sensors can also be supplied by Castflow Valves). the bushing assures tightness between the valve body and the sensor. Also it is adjustable in order to calibrate the sensivity.

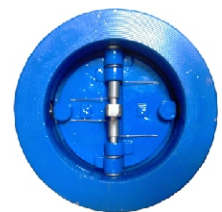
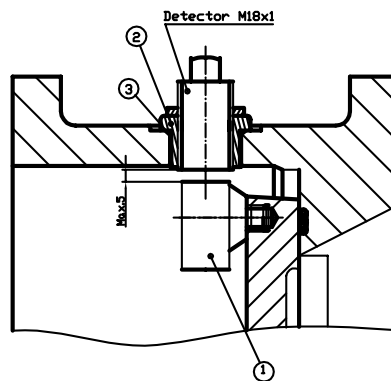

## Platos perforados para calderines anti golpe ariete / *Hole drilled plates for anti pressure surge vessels*

En instalaciones de bombeo el golpe de ariete la selección de retenciones es importante. Las más óptimas suelen ser de tipo nozzle, pero debido a su peso y dimensiones suelen tener un coste elevado. En lugar de alternativas como válvulas convencionales con by-pass o con elementos auxiliares para amortiguar los golpes, en Castflow podemos fabricar valvulas de doble clapeta con orificios perforados en los platos. Dichos orificios permitirán aliviar el aumento de presión aguas abajo.

On pump applications where pressure surge is anticipated, the selection of the check valve is important. The most suitable valves are nozzle check, however due to its weight and sizes they often result high costly. Instead of conventional valves with dampers or bypass to reduce water hammer, Castflow can foresee the valve plates with hole drilling. These holes will relieve the excess pressure increase downstream side.

